

ROLUSO ENTERPRISE Cummins Series

Product introduction

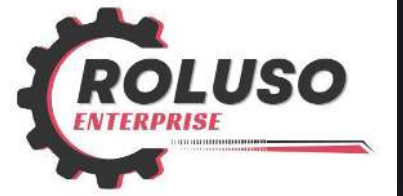

Model AC125 Generator set

113KVA/90KW

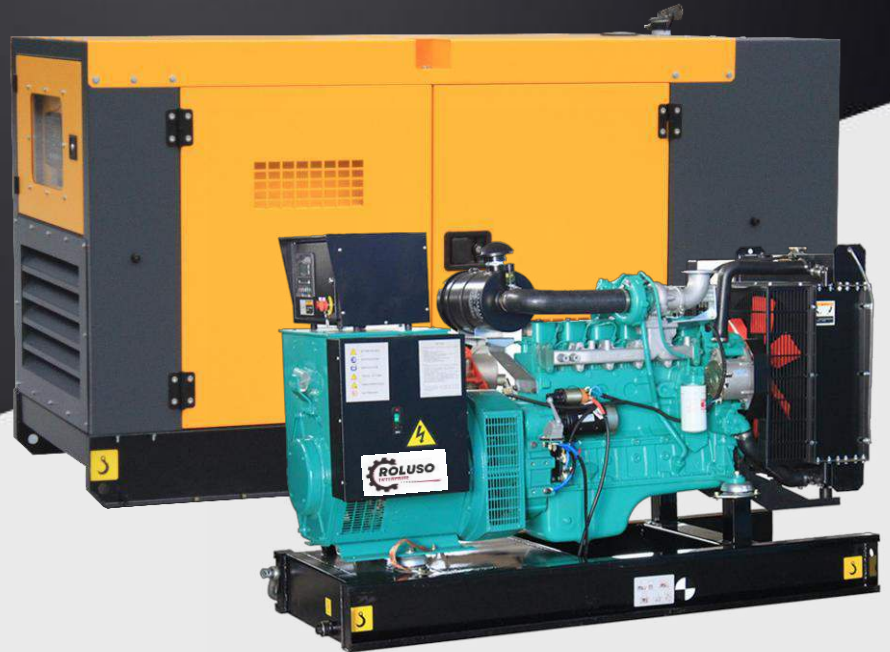

Roluso Enterprise

General Performance Data

Prime Power	113KVA/90KW	Engine	Brand	Cummins
Stand by Power	125KVA/100KW		Model	6BT5.9-G2
Frequency/Speed	60Hz/1800rpm	Control module	Deepsea 6120	
Rated Power Factor(cosφ)	0.8	Rated Current	295A	
Standard Voltage	127V/220V	Capacity of Breaker	400A	
Phases	3	Starting Voltage	DC24V	

Fuel consumption

Rated output	Fuel consumption rate	
	100%Standby	235 g/KW.h
100%Prime	235 g/KW.h	28.5 L/h
75%Prime	228 g/KW.h	20.7 L/h
50%Prime	238 g/KW.h	14.4 L/h
25%Prime	297 g/KW.h	9.0 L/h

Standards followed

ISO9001	ISO14001
ISO8528	ISO12100
ISO13849	EN12601
GB12786	GB/T2820
IEC60034	IEC60204
CE	RETIE

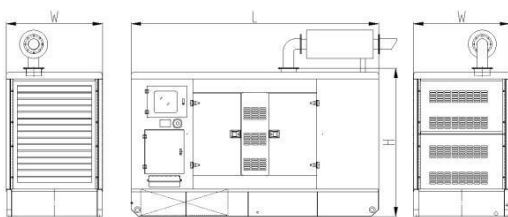
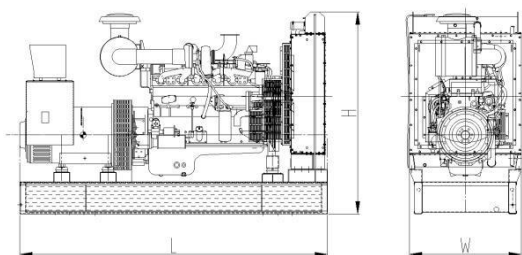

Dimensions and Weights

Type	Open	Silent
Length(mm)	2070	2900
Width(mm)	800	1100
Height(mm)	1450	1800
Weight(kg)	1150	1700
Base fuel tank volume (L)	170	170

Engine specification

Basic parameter

Manufacturer	dongfeng Cummins
Model	6BT5.9-G2
No. of cylinder	6
Type	4 cycle, Vertical In-line
Prime Power	100kw /133HP
Standby Power	110kw /147HP
Induction system	Turbocharged
Governor	Electronic speed
Bore x Stroke	102x120mm
Displacement	5.9L
Compression ratio	17.3:1
Oil Capacity(Total)	16.4L
Coolant Capacity(Engine only)	7.9L
Cranking Motor Voltage	DC24V

Fuel System

Type Injection system	BYC Type A inline pump
Min. Allowable flow of fuel to fuel pump	31.3 L/h

Lubrication system

Oil Pressure	
---Idle speed	207kPa
---Rated speed	345kPa
Max. allowable oil temperature	121°C
Offset sump oil capacity: low/high	14.2 /12.3L
Total system capacity	16.4L

Air induction system

Maximum allowable intake air restriction	
---with clean filter element	3.7kPa
---with dirty filter element	6.2kPa
Intake Air alarm temperature	82°C

Exhaust system

Max. allowable back pressure	10kPa
Standard exhaust pipe diameter	75mm

Cooling system

Coolant capacity	
---Engine only	7.9L
---Total system	22.4 L
---With heat exchanger	14.5L
Standard thermostat(modulating) range	82-95 °C
Minimum cap pressure	69kPa
Max. allowable top tank temperature for stand by/prime power	104/100 °C

Electric system

Min. recommended battery capacity (24V)	
---10°C(50°F) & above- 0°F CCA	400
--- 0°C(32°F) to 10°C(50°F)- 0°F CCA	400
---18°C(0°F) to 0°C(32°F)- 0°F CCA	400
Max. allowable resistance of Starting circuit	0.002ohm
Starter(heave,Anode)	DC24V
Battery recharge system, negative ground	40ampere

Alternator specification

Phases	3	Coating	Vacuum impregnation
Poles	4	Insulation class	H
Power factor(cosφ)	0.8	Protection	IP23
Winding connection	Star	Excitation system	Self-excited
Winding pitch	2/3	Bearing	Single Bearing
Voltage regulator type	AVR	Coupling	Flexible disc

Control system Introduction

Deepsea 6120 Auto start & auto mains failure control panel

Deepsea 6120 is an auto mains failure controller for single generator, it can monitor and protect the generator working all the time. it has a LCD display which clearly shows the status of the engine. this controller include seven inputs and six outputs. This controller can also be programmed using the front panel or by using DSE configuration Suite PC software

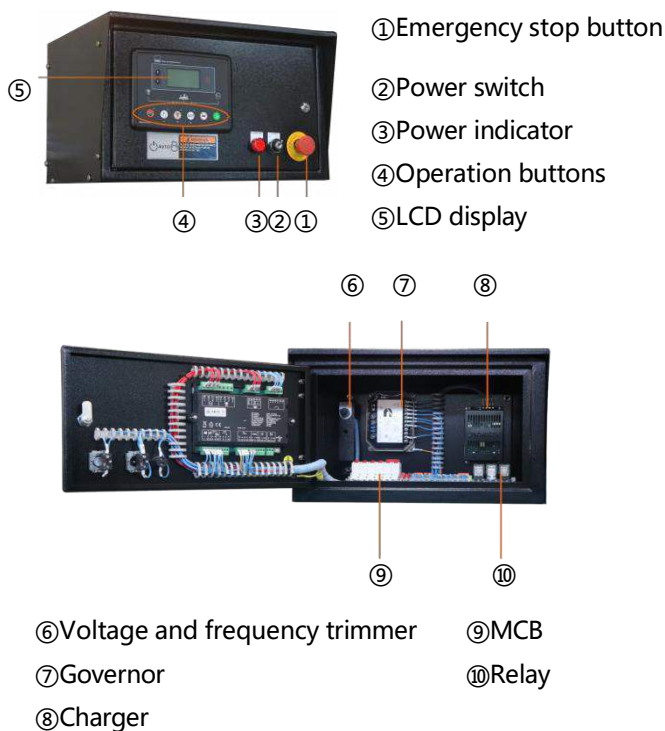

Key Features:

- Auto start/stop, load transfer and alarming of generator
- Remote start on or off load
- With hierarchical loading function
- Multiple start/stop cycles can be preset
- 3 phase generator and mains voltage monitoring.
- Generator/load power detection(kW, kVA, kVA_r PF)
- Overload protection (kW)
- Load current monitoring and protection
- Engine speed protection
- Engine pre-heat
- Engine start idle & stop idle
- Battery voltage monitoring
- Start under the low battery
- 4 active outputs
- 4 digital inputs and 3 analogue inputs.
- 6 Custom digital input
- 6 outputs(4 configurable on magnetic pick-up, 6 configurable on Canbus version)
- DSE2130,DSE2157,DSE2548 expansion module can be connected
- Support 0-10V or 4-20mA oil pressure sensor

Main features:

- Multi language display
- Mains failure self starting
- The running time of the engine can be recorded to facilitate the maintenance and repair of the unit
- User-friendly set-up and button layout
- LCD display can display multiple parameters at the same time
- Support EFI engine
- IP65 rating (with optional gasket)
- PC and front panel configuration
- 100 event records
- Data recording and trend analysis

Protection:

- Two sets of protection parameters can be preset
- Normal alarm, electrical trip and shutdown alarm can be set to effectively monitor the engine speed,oil pressure, water temperature and oil level, as well as the frequency, voltage, current and power of the alternator, for complete engine/alternator protection
- Low Oil Pressure
- High water Temperature
- High voltage and low voltage
- Overspeed
- Emergency stop
- Fail to start

Soundproof Canopy Introduction:

Silent Type :

- The vertical angle structure makes the appearance beautiful
- High quality coating powder, chemical surface treatment & 100-120um coating thickness greatly improving the anti-corrosion and anti rust level
- carbon hinge & door lock are beautiful and anti-rust
- 1.8mm cold rolled plate used makes the body more solid
- The bottom forklift and loading port design enables easy loading and unloading
- 180° revolvable and disassemble door for easy maintenance.
- The drainage outlets are all connected to the outside for easy operation
- The sufficient air in & out design ensure long-term and stable operation of the unit
- Isolation net is designed for air inlet, exhaust outlet and muffler outlet to prevent objects from entering the unit
- High density foam used inside effectively reduces noise
- The built-in base fuel tank with fuel filler set on the shell facilitates refueling
- Emergency stop button mounted on the canopy exterior for urgency.



Decomposition diagram introduction of Typical Canopy

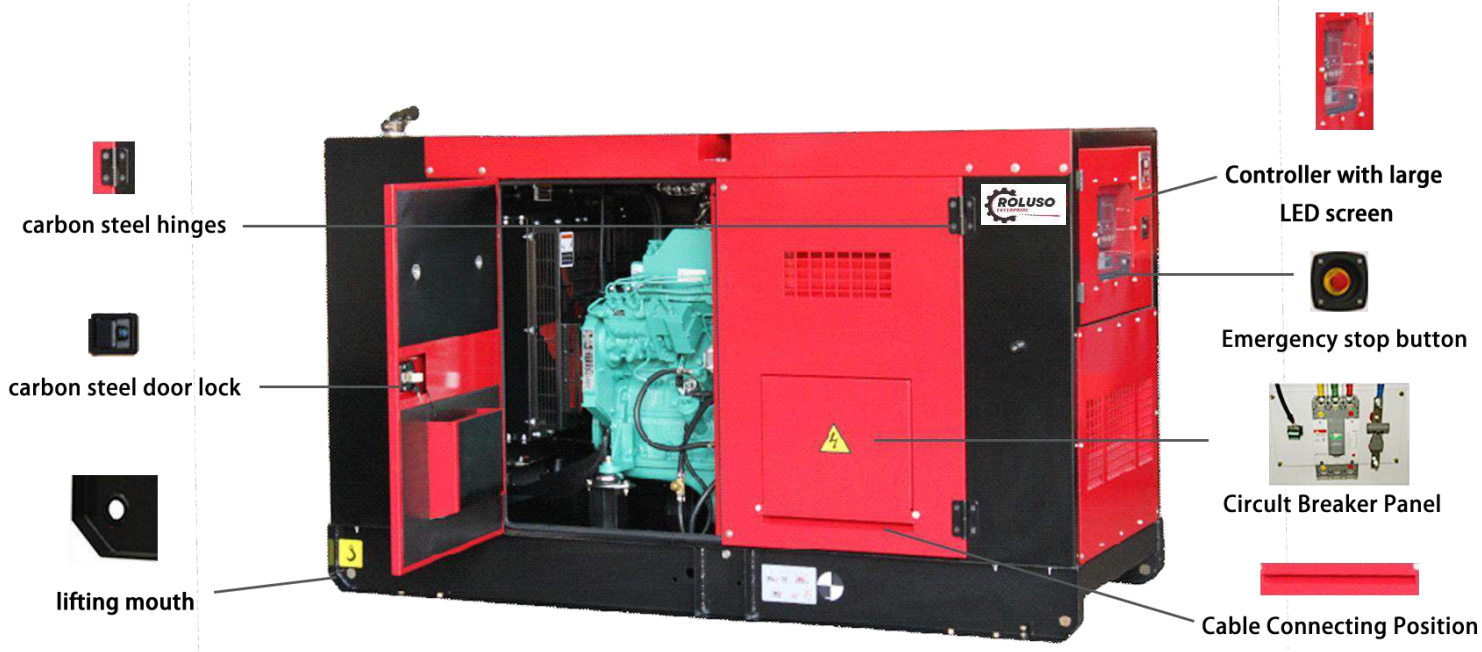

Standard supply scope:

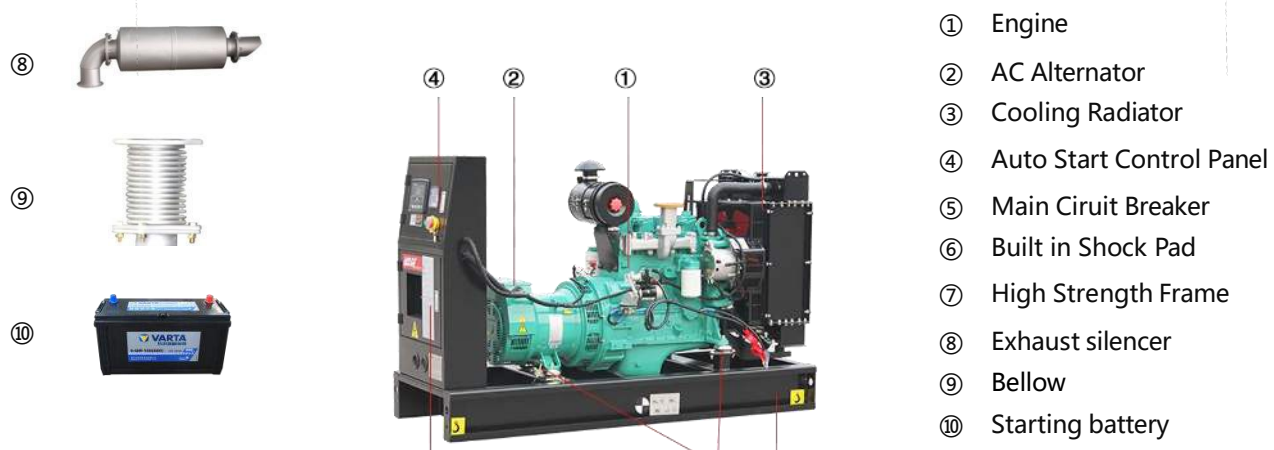

Optional supply scope:

Genset	Engine	Alternator	Control system
<ul style="list-style-type: none"> ● Tool box ● Base fuel tank ● External daily fuel tank ● Trailer 	<ul style="list-style-type: none"> ● Fuel heater ● Fuel and water separator 	<ul style="list-style-type: none"> ● Temp. detector for winding and bearing ● PMG ● Antirust, mildew and salt fog treatment ● Anti condensation heater 	<ul style="list-style-type: none"> ● ATS ● Synchronization System ● Adjustable earth relay
Breaker	Fuel system	Lub-oil system	Cooling system
<ul style="list-style-type: none"> ● ABB ● Schneider 	<ul style="list-style-type: none"> ● Low fuel level alarm ● Auto Fuel Pump ● T Valve 	<ul style="list-style-type: none"> ● Lub oil heater ● Temp.-sensor ● Oil drain Pump 	<ul style="list-style-type: none"> ● Elec.coolant Heater